

Contents

1. Warning	1-2
2. Product Feature	2
3. Product Component	3
4. Product Appearance and Control Configuration	4
5. ETS/ETM MCCB Connection	6
6. Product Rating	7
7. Operating Method	8
8. Relay Element Testing Method	9

1. Warning

Thoroughly read user manual before usage for safe use and to fully understand features of MCCB Tester, Please keep user manual near the MCCB Tester

Symbols used on product and in user manual represents following warnings:

& Warning Appears when instructions are violated, and there is possibility of serious injury or death

& Caution Appears when instructions are violated, and there is possibility of minor injury or product damage

& Appears under certain condition where there is risk of danger and user should pay attention

4. Product Appearance and Control Configuration

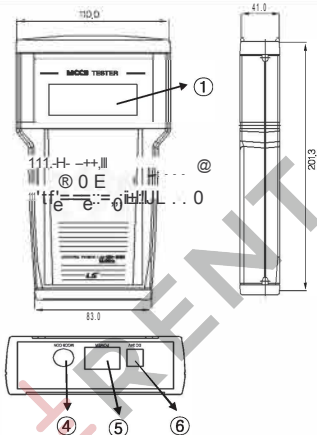

NO.	Button Type	Feature
e	LCD	Display test setting current and test result
e	LED	Display set frequency
e	BUTTON	Display moving and setting of the menu
⓪	Signal Output Terminal	MCCB connecting terminal
⓪	Power Switch	Power ON/OFF
⓪	Adapter Terminal	Control power terminal of the tester

& Warning

- Do not operate, check or install alone.
- Do not carry out a test when MCCB is powered or while operating
 - It may cause electric shock or malfunction of MCCB
- Do not carry out a test if the bus is in live-wire state.
 - It may cause electric shock and the charging voltage of current transformer may be damaged or cause fire.
- Do not carry out a test when MCCB control is powered
 - It may cause electric shock or malfunction of MCCB
- Do not disassemble the product even when unpowered.
 - Internal charging current of the product may cause electric shock.
- Do not install or operate with wet hands. It may cause electric shock.
- Do not use if the sheath of cable is damaged.
 - It may cause electric shock.
- Please wear necessary protection for usage.
- Please attach safety caution before operating.

& Caution

- Precautions for installation and terminal wiring.
 - ▶ Please apply correct power which suits rating of power terminal.
 - Violation of this caution may cause product damage or fire.
- Do not allow screws or other metal materials, water, oil or other substances enter inside the product.
 - Violation of this caution may cause product damage or fire.
- Please check the direction before connecting the connector to terminal input/output.
 - Violation of this caution may cause product damage or fire.
- Please use the offered adapter
 - Violation of this caution may cause product damage or fire
- Checklist before inserting power.
 - ▶ Check voltage and polarity of control power
 - ▶ Check cable direction of tester and MCCB
- Please change the battery if product fails to operate without additional power supply.
- Precautions for storage and handling.
 - ▶ Please store in area where there is no moisture or dust.
 - ▶ Do not throw or add strong force when moving.
- Precautions for disposal.
 - ▶ When disposing, treat it as industrial waste disposal

2. Product Feature

- (1) Susol ETS/ETM Tester (shortened as TESTER) performs current relay test of Susol ETS/ETM MCCB (shortened as MCCB)
- (2) To perform relay test of ETS/ETM MCCB, TESTER can set current amplitude
- (3) TESTER is equipped with built-in high-performance MCU to perform precise current relay test.
- (4) TESTER Displays fault (accident) that may occur on MCCB LED, as well as trip time and current value of the trip
- (5) The output current of TESTER has a 10% tolerance
- (6) For self-protection, the output of TESTER current lasts only up to 1500 seconds.

4. Product Appearance and Control Configuration



NO.	Button Type	Feature
1	ESC	Go back to the main screen
2	↑	Increase the set value
3	↓	Decrease set value
4	ENTER	Save set value setting
5	START	Begin waveform generation
6	STOP	Stop waveform generation
7	Hz	Change frequency

3. Product Components



5. MCCB Connection

5-1. MCCB Connecting Method

Connect the other-side of cable to MCCB

- When connecting Signal Cable to MCCB, please plug the cable in correct direction.
- Tester uses 6-pins connector and MCCB uses 2 or 6-pins connector.

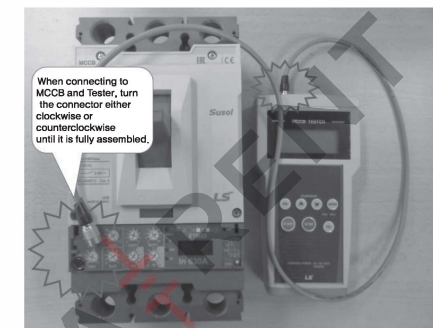

Note)

- 1 Do not carry out a test when MCCB control is powered.
- 2 Do not turn on control power of MCCB while connected to the Tester.
- 3 After connecting MCCB to the Tester, turn on the Tester and press any buttons to apply the power to MCCB.
- 4 When the test is completed, press ESC button for 1 second back to previous menu.

6. Product Rating

6-1. Standard Usage environment

Unless there was a special condition mentioned, please follow the standard conditions below.

- 1) Temperature
 - Standard using temperature: -10°C ~ 55°C
 - Storage temperature: -25°C ~ 70°C
- 2) Humidity : Then Humidity should be less than 80% where there's no dew anytime.
- 3) Using environment condition
 - Altitude : below 2,000m.
 - Area where there is no abnormal vibration or shock.
 - The surrounding air should be clean.

&2. Product Input Rating

Classification	Applied Limits	Note
Rating Frequency	60Hzor50Hz	
Rating Input	AC100~240V	
Power Consumption	Under 60W	

7

7. Operating Method

7-1. Output Signal Amplitude, Setting and Testing Method

7-1-1. Initial Screen

1. ETS/ETM43
2. ETS/ETM33
3. ETS23



- 1) MCCB Type can be selected by using UP/DOWN buttons.
- 2) Press Enter key once, go to next menu

7-1-2. Rated current setting Screen

2. ETS/ETM33
- Select Current 4/4
- 630A



- 1) MCCB Rated Current 'In' can be selected using UP/DOWN button
- 2) Press Enter key once, go to next menu
- 3) Press ESC key once, Back to previous menu.

7-1-3. Test screen

2. ETS/ETM33 630A
- Trip 00063.125s
- I Test off
- 2.0 In 1260 A



- 1) 'In' can be selected using Up/Down button
- 2) If you press ENT key one more time, the cursor will be moved to first decimal digit. When press twice, the cursor will be moved to second decimal digit.
- 3) Press Start key once. Tester will send output signal.

8

8. Relay Element Testing Method

&-1. Long Time

- 1) Change MCCB setting value
 - refer to Standard table for Long Time Relay before setting.
 - Set other relay elements (I_{sd} / I_r) to MAX.
- 2) Change Tester setting value
 - refer to Standard Table for Long Time Relay before setting.
- 3) Press START button.
- 4) The trip will be operated after the count down.
 - Also, time count will be displayed on Tester LCD screen
 - Please check whether the trip operated within the standard time period.
- 5) Check the normal operation factors(parts) by LED of MCCB(only ETM).

Standard Table for Long Time Relay

NO.	Setting Condition				Tester AMP	Operating time (sec)	
	MCCB					Cold	Hot
	ETM		ETS				
I _o	I _r	I _r	t _r				
1	0.5	0.8	0.4	6	2	6~12	2~4
2	0.5	1	0.5	6	2	9~19	3~7
3	0.6	1	0.6	6	2	14~27	4~10
4	0.7	1	0.7	6	2	20~38	6~13
5	0.8	1	0.8	6	2	27~50	9~18
6	0.9	1	0.9	6	2	35~65	12~24
7	1	1	1	6	2	45~84	16~32

9

8. Relay Element Testing Method

&-2. Short Time

- 1) Change MCCB setting value
 - refer to standard table for Short Time Relay before setting.
 - Set other relay elements (I_o-only ETM) to MAX.
- 2) Change Tester setting value
 - refer to Standard Table for Short Time Relay before setting.
- 3) Press START button.
- 4) Repeat step 4~5 in section 8-1.

Standard Table for Short Time Relay

NO.	Setting Condition						Tester AMP	Operating time (sec)
	MCCB							
	ETM		ETS		I _{sd}	t _{sd(off)}		
I _o	I _r	I _r	I _r					
1	0.5	0.8	0.4	1.5	0.3	0.8	0.03-0.07	
2	0.5	0.8	0.4	1.5	0.3	0.8	0.24-0.35	
3	0.5	0.8	0.4	5	0.05	2.5	0.03-0.07	
4	0.5	0.8	0.4	5	0.3	2.5	0.24-0.35	
5	0.5	0.8	0.4	10	0.05	4.5	0.03-0.07	
6	0.5	0.8	0.4	10	0.3	4.5	0.24-0.35	
7	1	1	1	1.5	0.3	1.9	0.03-0.07	
8	1	1	1	1.5	0.3	1.9	0.24-0.35	
9	1	1	1	5	0.05	6	0.03-0.07	
10	1	1	1	5	0.3	6	0.24-0.35	
11	1	1	1	8	0.05	9	0.03-0.07	
12	1	1	1	8	0.3	9	0.24-0.35	

10

8. Relay Element Testing Method

&-3. Instantaneous Time

- 1) Change Tester setting value
 - refer to Standard Table for Instantaneous Time Relay before setting.
 - Set other relay elements (I_r / I_{sd} / I_g) to OFF.
- 2) Repeat step 4~5 in section 8-1.

Standard Table for Instantaneous Time Relay

NO.	Setting Condition				Tester AMP	Operating time
	MCCB					
	ETM		ETS			
I _o	I _r	I _r	I _i			
2				1.5	1.7	Within 50ms
1				2	2.2	
1				3	3.2	
1				4	4.2	
2				5	5.3	
1				6	6.5	
1				8	8.5	
1				10	11	
1				11	12	

h Standard does not influence operating time with any value setting

ETS Fixed at 11

11

Purchase Enquiry

Seoul Sales Team	TEL : (02)2034-4553~54	FAX : (02)2034-4555
Busan Sales Team	TEL : (051)31 0-6821 ~24	FAX : (051)310-6827
Changwon Sales Office	TEL : (055)282-9812	FAX : (055)282-4352
Ulsan Sales Office	TEL : (052)261-1585	FAX : (052)261-4205
Daegu Sales Team	TEL : (053)603-7711~13	FAX : (053)603-7777
Pohang Sales Office	TEL : (054)286-4528	FAX : (054)286-2813
Gwangju Sales	TEL : (062)510-1881~22	FAX : (062)528-7684
Jeonju Sales Office	TEL : (063)271-4014~16	FAX : (063)271-2613
Daejeon Sales	TEL : (042)820-4201 ~07	FAX : (042)820-4298

Technology Enquiry

Customer Center TEL : 1544-2080 FAX: (041)550-8600

A/S Enquiry

Seoul Service	TEL : 1544-2080	FAX : (02)3660-7021
Busan Service	TEL : (051)988-2080~1	FAX : (051)310-6827
Changwon Service	TEL : (055)602-2080	FAX : (055)282-4352
Ulsan Service	TEL : (052)261-1585	FAX : (052)261-4205
Daegu Service	TEL : (053)603-2081 ~2	FAX : (053)603-7777
Pohang Service	TEL : (054)286-4528	FAX : (054)286-2813
Gwangju Service	TEL : (062)527-2080	FAX : (062)528-7684
Jeonju Service	TEL : (063)254-2080	FAX : (063)271-2613