

Solmetric Site Evaluation and System Design



Integrated hand-held tool for solar site evaluation and shade analysis.

That means:

- Easy, accurate measurements and instant feedback
- Fast estimates lead to quick sales and designs
- Data is automatically stored for later review and design



**Expert Tools.
Better Solar.**

Fast, Accurate, Professional

The Solmetric **SunEye 210** represents the next generation for solar energy professionals doing site evaluation and energy production estimates. With a unique approach that combines a calibrated fisheye lens with electronic tilt and compass sensors, the **SunEye 210** brings a new level of accuracy and convenience.

Key Features

- Electronic Inclinometer
- Electronic Compass
- Single-Handed Operation
- Rugged, Comfortable Design
- 2 Year Warranty Worldwide
- Integrated GPS (Optional)
- Live Survey Mode—view annual sunpaths live as you walk the site
- High capacity battery
- Digital camera with Fisheye lens
- “What if” editing of sunpath obstructions with new scenario storage



Measuring roof pitch is now integrated into the SunEye 210. Simply lay it on the roof or module and read tilt and heading.



On-site Challenges Solved

- Rooftop measurements from ground level with the SunEye Extension Kit to elevate the SunEye up to 5.4m (18 feet)
- Accurate readings on metal rooftops using “Target” mode to align without the compass
- Identifying shade-free area using “Windowed-Access” to specify a month and time of day range within which solar access is calculated
- Quick capture mode for minimizing time on roof
- True one-handed operation in which the SunEye no longer must be held level and south for accurate readings

SunEye™ 210

Take a closer look



Digital Camera with Fisheye Lens

Built-in stylus holder

Impact resistant molded body contains post-consumer plastic

Bright Hi-Resolution VGA Touch screen Display

Annual Sunpaths View
Other views include monthly Solar Access, obstruction elevation angles, and fisheye image

Standard USB-Mini connector transfers SunEye data to Desktop Companion PC software. Edit and export professional reports from your PC

Display of Solar Access and Panel Orientation

Home Button

5-way Navigation Keys. Handy center key snaps picture for one handed operation

Quick Launch Buttons: Orientation Mode and Quick Measure

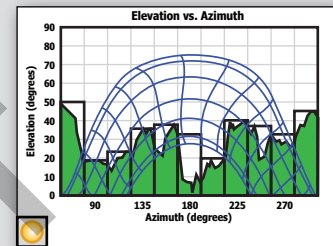
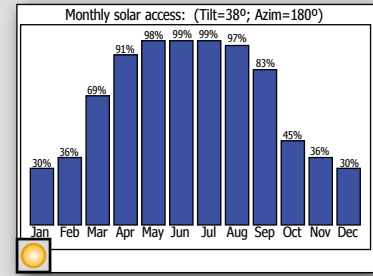

Alternative data views include monthly solar access and obstruction elevation vs. azimuth.

Included with the SunEye:

Hard case with foam cutouts, Stylus, AC Charger, USB Cable, Installation DVD, Desktop software, Lens Cap and Quick Start Guide

Solmetric products that enhance the SunEye:

Solmetric SunEye Extension Kit
Telescoping pole, SunEye plate and Quick Start Guide

PV Designer

Yearly subscription through SunEye Desktop Companion Software

Live Survey Mode displays a live video image with sunpaths superimposed. Quickly walk the site identifying shade-free regions.



Target mode enables accurate measurements even when nearby metal distorts compass readings.

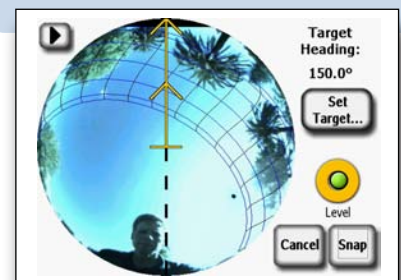

**Expert Tools.
Better Solar.**

SunEye Extension Kit



Extension Kit Interface

When using the Extension Kit, SunEye skylines are captured by rotation of the pole combined with audio feedback from the SunEye. The SunEye will automatically correct the measurements for azimuth and tilt using inputs from the on-board sensors.

Elevate Your Shade Measurements

In many situations, shade measurements are needed but you cannot get yourself into the right position. For example, roof access may be difficult or not allowed. Or a proposed solar structure is not yet built. Calculations can be difficult and error-prone.

The SunEye Extension Kit enables accurate measurements up to 5.4m (18 feet) above ground level. It consists of a telescoping extension pole with a plate at the top to hold the SunEye 210 securely. The plate holds the SunEye secure and protected without obstructing the field of view of the SunEye's camera lens.

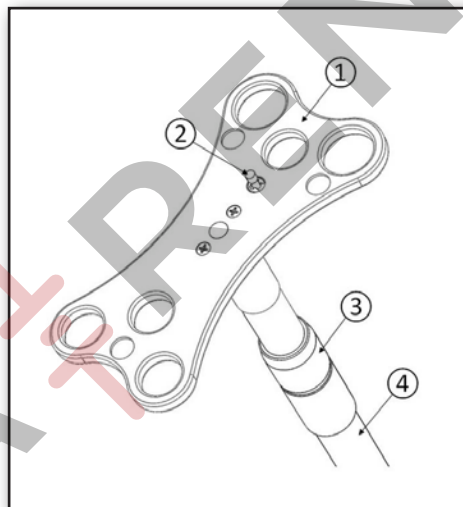

Key Features

- Lightweight and rugged
- Non-conductive
- Extends to 5.4 meters (18 feet)
- Collapses to 1.5 meters (4.9 feet)

SunEye Extension Kit Parts

1. Plate
2. Mounting Screw
3. Easy-grip extender
4. Telescoping Extension Pole



**Expert Tools.
Better Solar.**



Extension kit enables rooftop measurements from ground level.

PV Designer Software

With PV Designer you can compare the estimated energy production in multiple what-if design scenarios.

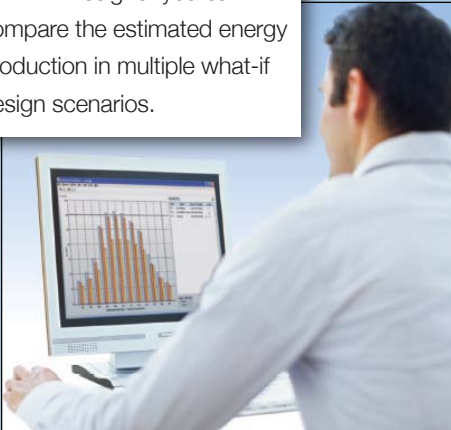

Build winning proposals

- Create high impact visuals
- Experiment easily with alternative configurations
- Export data to your application for further analysis and proposals

Fast, Easy, Visual PV Design

In addition to the SunEye desktop software included with the SunEye, Solmetric offers powerful software for the design of solar photovoltaic (PV) systems. PV Designer offers module layout and shade-adjusted energy production estimates in a complete integrated software tool.

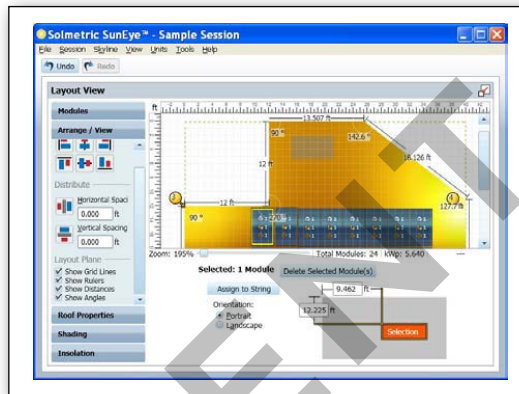

Visualize your PV designs

- Create arbitrary roof shapes and specify set-back and keep-out regions
- Drag and drop modules on roof
- Define strings and adjust module positions
- Drag and drop shade measurements from SunEye readings

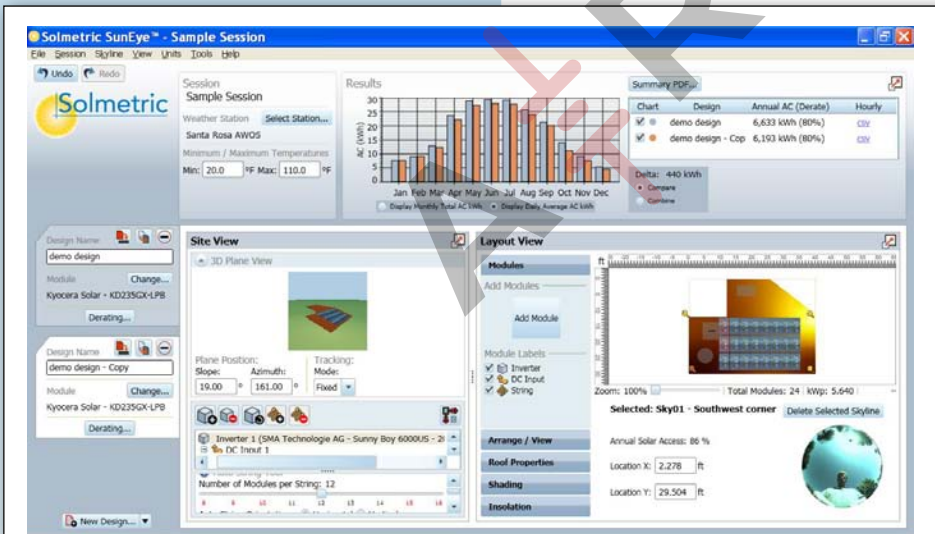

See on-line tutorial at: www.solmetric.com

Powerful Modeling

- Includes local weather database
- Choose modules and inverters from an extensive database with key specifications
- Check string sizing vs. inverter limits
- Display monthly, daily average and annual energy output
- Visualize shade impacts over roof area
- Optimize solar access and AC kWh production



**Expert Tools.
Better Solar.**

Headquarters:

117 Morris Street, Suite 100
Sebastopol, CA 95472
www.solmetric.com
info@solmetric.com
Tel: +1-707-823-4600
Fax: +1-707-823-4620

Also from Solmetric:

PV Analyzer IV curve tracer for quick and accurate commissioning and troubleshooting.



A RENT

a-rent.com

(IL) 630.748.8900
(TX) 713.564.8900

sales@a-rent.com