

# Installation/Maintenance Instructions

## Solid State Trip Device and Test Set

### *Power Shield<sup>®</sup> - Solid State Trip Device (Gray Case) and Type 504 Test Set*

FOR CIRCUIT BREAKER TYPES, K-800S, K-2000S, K3000S, K4000S,  
K-DON<sup>®</sup> - 600S, K-800S and 1600S

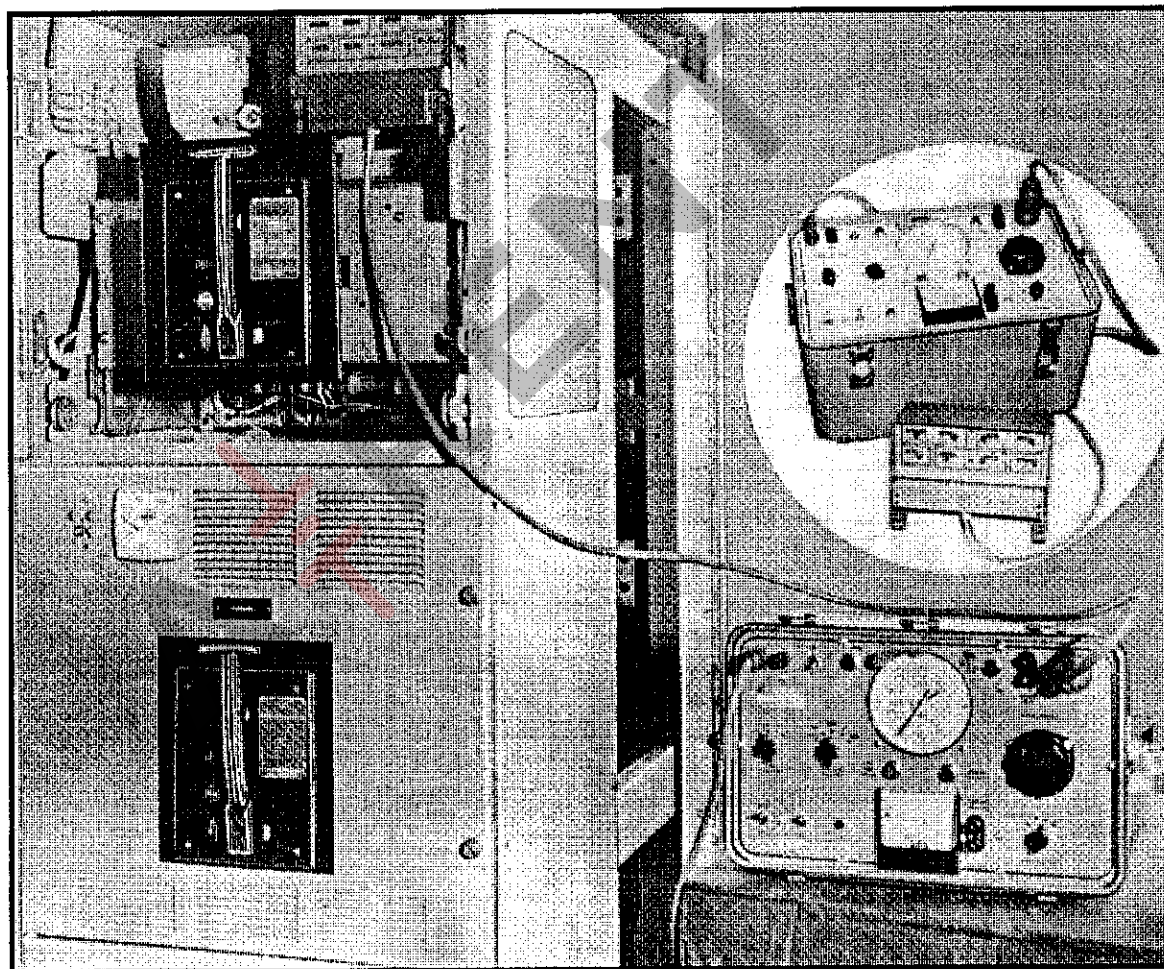

**ABB Power Distribution, Inc.**  
**Circuit Breaker Division**

**ABB**  
ASEA BROWN BOVERI

## TABLE OF CONTENTS

	PAGE		PAGE
POWER SHIELD-Solid State Trip Device .....	3	2.7.2 Delay Test .....	7
1.1 Introduction .....	3	2.8 Sensor Checks .....	7
1.2 Operating Principles .....	3	2.8.1 Sensor Continuity .....	7
1.3 Available Settings .....	3	2.8.2 Sensor Grounding .....	7
1.4 How to Make Settings .....	4	2.9 Motor Alarm Test .....	7
1.5 Operation Indicator .....	4	3.0 Appendix .....	10
1.6 Load Alarm .....	4	3.1 Primary Current Testing .....	10
2.0 POWER SHIELD-Test Set .....	5	3.2 Primary Testing of a Four-Wire Double-Ended Substation (DE4W) Breaker .....	11
2.1 General Requirements .....	5	3.3 Description of Ground Fault Protection System for Four-Wire Double-Ended Substation ..	12
2.2 Description of Controls .....	5	Test Sheet .....	13
2.3 Circuit Breaker Accessibility .....	6	Test Set Trouble Shooting Guide .....	14
2.4 Long Time Function .....	6	Test Set Schematic Diagram .....	15
2.4.1 Pick-Up Test .....	6	POWER SHIELD Time-Current Characteristics .....	16
2.4.2 Delay Test .....	6	TABLES	
2.5 Instantaneous Function .....	6	1- POWER SHIELD Standard Tables .....	2
2.5.1 Pick-Up Test .....	6	2- Long-Time, Instantaneous and Short-Time Pick-Up Currents .....	8
2.6 Short-Time Function .....	6	3- Ground Pick-Up Currents .....	8
2.6.1 Pick-Up Test .....	6	4- Trip Times .....	9
2.6.2 Delay Test .....	6		
2.7 Ground Function .....	7		
2.7.1 Pick-Up Test .....	7		

**TABLE 1 — POWER SHIELD STANDARD TYPES**

Solid-State Trip Device Type*	Trip Element				Time-Current Characteristic Curve	Usage
	Long- Time	Short- Time	Instan- taneous	Ground **		
SS-3	X		X		TD-8001	General Purpose
SS-3G	X		X	X		
SS-13 SS-13G	Same as above, but with longer LONG-TIME delays.					
SS-4	X	X			Shown on TD-8002	Dual Selective
SS-4G	X	X		X		
SS-14 SS-14G	Same as above, but with longer LONG-TIME delays.				Shown on TD-8004	
SS-5	X	X	X		TD-8002	Triple Selective
SS-5G	X	X	X	X		
SS-15 SS-15G	Same as above, but with longer LONG-TIME delays.				TD-8004	
SS-7			X		Shown on TD-8001	Instantaneous Only
SS-7G			X	X		
SS-10		X			Shown on TD-8002	Short-Time Only
SS-10G		X		X		

\* Types SS-13, SS-13G, SS-14, SS-14G, SS-15, and SS-15G are applied primarily to motor circuits having long accelerating times.

\*\* For Ground Curves refer to TD-8005.

These instructions do not purport to cover all details or variations in equipment nor to provide contingency to be met in connection with installation, operation, or maintenance. Should further information be desired or should particular problems arise which are not covered sufficiently for the purchaser's purposes, the matter should be referred to the nearest District Office.

**1.0 POWER SHIELD — SOLID STATE TRIP DEVICE**

**1.1 INTRODUCTION**

“POWER SHIELD” is a solid-state trip device used to protect the power system against damage caused by overloads and faults. It is supplied as an integral part of the circuit breaker, types K-600S through K-4000S, K-DON® 600S, K-Don 800S and K-Don 1600S.

The long-time, short-time, and instantaneous trip elements perform essentially the same protective functions as provided by the electro-mechanical trip devices, but with greater accuracy and selectivity. See Table 1, page 2.

The ground-trip function can be included in any model for those applications in which it is desired to protect the system against faults to ground. These are often arcing faults which result in currents whose magnitude is less than normal load current, but require detection due to the damage which may result from the arc.

“POWER SHIELD” is completely tested prior to shipment. Since there are no mechanical devices which may have lost adjustment during shipment, no readjustments need be made prior to placing in service. Nor is maintenance required in the usual sense of cleaning, adjusting, or lubricating.

Electrical tests which may be made as part of a routine procedure are included in Sections 2.1 to 2.9.

The frequency of testing will vary from user to user depending on many factors. A typical interval of 1 to 2 years is suggested.

**1.2 OPERATING PRINCIPLES**

The trip device consists of the sensors, logic box, latch-release, and interconnecting wiring. There are two (2) sensors mounted on each primary conductor, one supplying the logic box with a signal current proportional to the primary current, the other supplying the power required to operate the latch-release and solid-state circuitry. The logic box contains the circuitry and the various tap-blocks used to set the overcurrent trip levels and time-delays. The magnetic latch release IS POWERED BY THE LINE OVERCURRENT, through the sensors and logic box.

The power-supply sensors provide the bias-power required for the electronic circuits, as well as the power required for the latch-release. The power-supply sensor output is switched to the latch release on command of the logic box, when the primary current exceeds the selected magnitude and time-delay.

The signal-sensors operate similar to current transformers and supply the logic box with a current proportional to the primary current. As shown in Figure 1, the secondary current,

$$I_2 = I_1/N$$

$I_2$  is rectified in the LOGIC BOX, and is burdened with a resistor R, which is selected by placement of the ampere tap plug. Thus, a voltage,  $V_2$ , is developed across R, which voltage is proportional to both the primary and secondary currents  $I_1$  and  $I_2$ . The electronic pick-up circuits are actuated by  $V_2$  if it exceeds the set level. Then the time-delay circuits are actuated to determine that  $V_2$  (and  $I_1$ ) has persisted for the required delay.

At the expiration of the delay time, the output circuit is triggered, enabling the power-supply sensors to deliver their power to the latch-release, thus opening the circuit breaker.

**1.3 AVAILABLE SETTINGS**

AMPERE-TAPS available on “POWER SHIELD” depend on the frame-size of the breaker. They are listed in Table 2.

The LONG-TIME pick-up may be set at 0.7, 0.8, 0.9, 1.0, or 1.1 times the chosen AMPERE-TAP. (See Table 2.) The LONG-TIME delay may be set at minimum, intermediate, or maximum delay band. “POWER SHIELD” is offered with two choices of long time delay bands, as described in Table 4.

SHORT-TIME pick-up may be set at 2, 3, 4, 6, 8 or 10 times the selected AMPERE-TAP. (See Table 2.) The SHORT-TIME delay may be set at minimum, intermediate or maximum as illustrated in Table 4.

INSTANTANEOUS pick-up may be set at 4, 5, 6, 8, 10 or 12 times the AMPERE-TAP. (See Table 2.) This function responds with no intentional delay as shown in Table 4.

GROUND pick-up current settings vary with the breaker and the AMPERE-TAP range chosen, as shown in Table 3. The delay may be set at minimum, intermediate, or maximum as shown in Table 4.

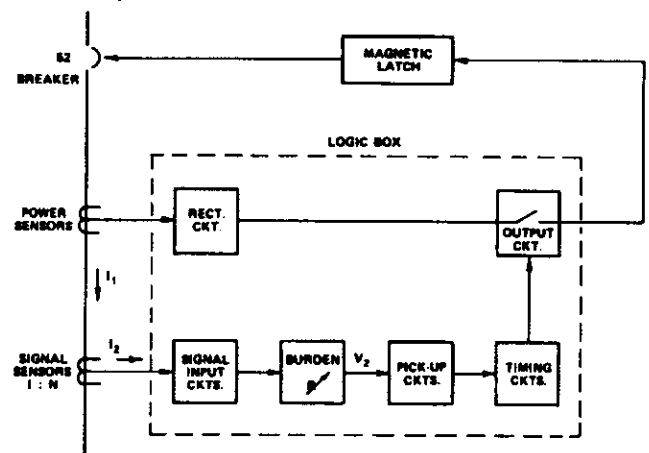

Fig. 1 — One Line Diagram

#### 1.4 HOW TO MAKE SETTINGS

The PICK-UP and DELAY settings for all trip functions are made by proper placement of the tap plugs on the front panel of the LOGIC BOX. If a tap plug is removed, the settings revert to minimum.

The long-time, short-time, and instantaneous trip functions are calibrated in terms of the AMPERE TAP setting. This setting is similar to the "coil-rating" of the electromechanical trip device. However, several AMPERE-TAP settings are available in the "POWER SHIELD". The AMPERE-TAP setting is made by placement of its tap plug on the front panel of the LOGIC BOX.

To set the long-time trip function, place the pick-up and time-delay plugs in their selected positions. This procedure is repeated for the short-time and instantaneous functions. The ground-trip function is calibrated directly in amperes. To set pick-up amperes and time delay, simply place the tap plugs in the selected positions of the tap block in the LOGIC BOX front panel.

As an example of the plug settings, consider the following example:

Breaker K-2000S, Trip Device Type SS-3.

Long-time pick-up desired 1600 amps.

(1) Set AMPERE-TAP plug at 2000 amps.

(2) Set LONG-TIME PICK-UP plug at 0.8; then L.T. pick-

up =  $0.8 \times 2000 = 1600$  amps.

(3) Set INSTANTANEOUS PICK-UP plug at 10; then INST. pick-up =  $10 \times 2000 = 20,000$  amps.

#### 1.5 OPERATION INDICATOR (Optional) (Orange Rotary Flag)

An operation indicator is provided WHEN SPECIFIED. This is a magnetic target indicating that a trip has occurred due to a fault current function. The normal arrangement provides for a single target indicating that a trip has occurred due to the operation of the short-time, instantaneous, or ground fault functions. An alternate arrangement can be provided for an indication of ground trip only. The indicators are reset manually by a small permanent magnet. No control power is needed for reset and the indicator cannot be shocked or vibrated into a false position. When a ground trip only target is specified, a contact for remote indication of this ground trip action can be provided as an optional feature.

#### 1.6 HIGH LOAD ALARM (Optional)

A load alarm is available that will close a contact when the primary current reaches a predetermined magnitude. The load alarm setting is continuously adjustable from 50% to 100% of the AMPERE TAP setting.

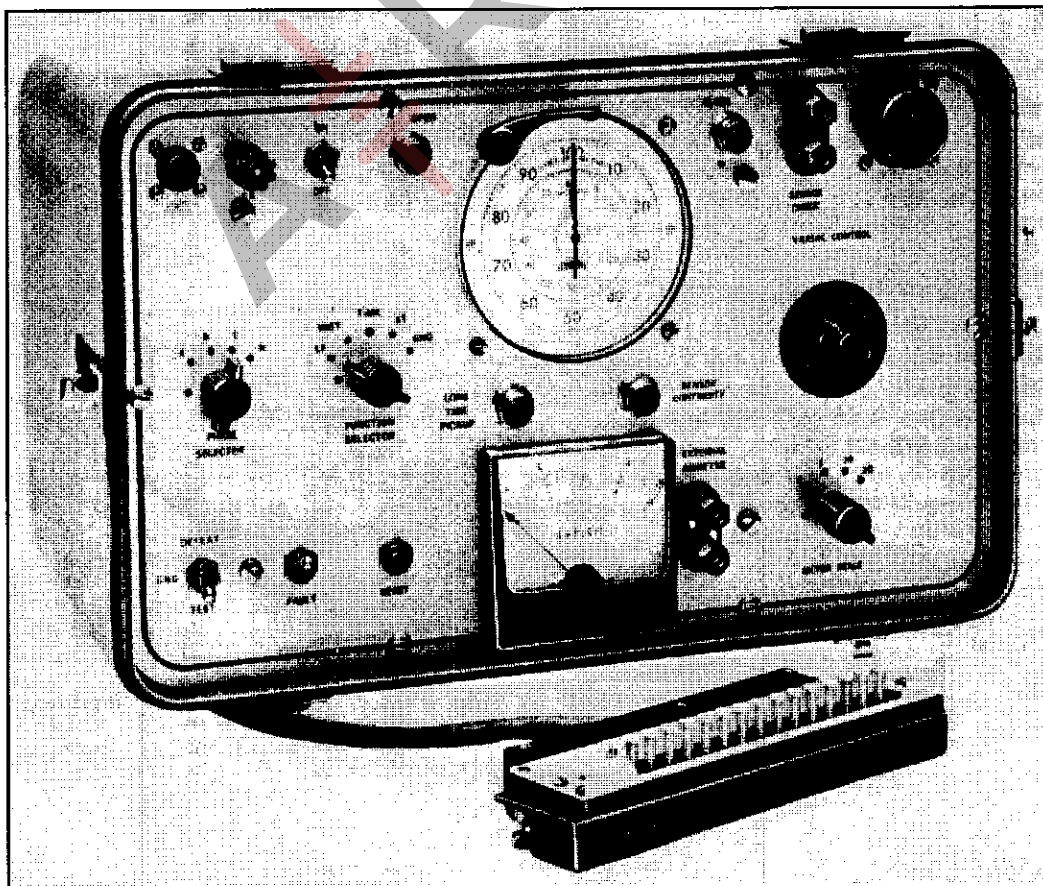

Fig. 2-Front View of Test Set Showing Location of Controls

## 2.0 POWERSHIELD — TEST SET

### 2.1 GENERAL REQUIREMENTS

The test set has been designed specifically for use with the "POWER SHIELD" trip device, and incorporates all the required test circuitry in a compact portable case.

These instructions should be used in conjunction with the basic circuit breaker instruction books as follows:

K-600S, K-800S, K-1600S, K-2000S . . . . . IB 6.1.2.7-1

K-DON-600S, K-DON-800S, K-DON-1600S .IB 6.1.2.7-3

K-DON-600S, K-DON-800S, K-DON-1600S,

K-3000S, K-4000S . . . . . IB 6.1.2.7-2

The required power is a 115V, 60 Hz., single phase, 5 ampere source.

In addition to testing the trip device pick-up and delays of the Long-Time, Instantaneous, Short-Time and Ground functions, ("on" or "off" the breaker) the test set may be used to confirm that the sensors and their wiring have continuity and are not shorted to ground. The test set will also confirm that the latch release, and the rest of the breaker's trip mechanism is functioning, by tripping the breaker through the LOGIC BOX.

To use the "POWER SHIELD TEST SET", connect the power cable to a 115V source and connect the test cable to the "POWER SHIELD" terminal block. It is unnecessary to remove the wires from the "POWER SHIELD" terminal block, unless otherwise indicated.

In testing a particular function, it will be necessary to move the plugs on the other functions to their maximum setting. However the existing setting must be noted so that they can be properly restored and overall coordination maintained as originally determined by the engineers. The plugs of the other elements should not be merely removed because this does not defeat the function, but rather allows it to revert to the minimum setting, and improper operation will occur.

#### NOTE 1

When testing "POWER SHIELD" units equipped with ground protection it will be necessary to set the GND switch in the DEFEAT position (lower lefthand corner of the test set) to test Long-Time, Instantaneous, and Short-Time delay functions. Set the GND switch in the TEST position to test ground trip functions.

#### NOTE 2

The CLOSE lamp must be lighted at the start of any test. If not, depress the RESET button and close the circuit breaker if desired.

#### NOTE 3

The "POWER SHIELD" functions can be tested with the circuit breaker in the open position if so desired. The trip and close lights on the test set will simulate breaker operation.

#### NOTE 4

Tolerances of  $\pm 15\%$  are suggested to account for field

testing variations. Actual tolerances are closer under factory test conditions.

#### NOTE 5

When testing "POWER-SHIELD" units off of the breaker, insure that the resistor leads are connected to terminals 3 and 16.

### 2.2 DESCRIPTION OF CONTROLS

#### Fuse Holder

The fuse is a standard AGC-3. (3 ampere, slow blow)

#### On-Off Switch

Removes power from test set circuitry. Retain in off position until all connections and settings are made.

#### Phase Selector Switch

Allows tests to be selected on individual phases. The "N" position is used when the "POWER SHIELD" device is a unit with a neutral sensor (4 wire system with ground).

#### Function Selector Switch

Selects which option is to be tested.

#### GND Switch

The switch defeats the ground option when testing phase functions.

#### Fault Switch

Applies a simulated fault condition.

#### Reset Switch

Resets the simulated breaker position to the closed condition .

#### Open and Close Lamps

Indicates position of the simulated breaker. (Lamps are type 1843)

#### Long-Time Pick-Up Lamp

Indicates when long-time pick-up has occurred. The lamp is operable only when the Function Selector is in the LT position. (Lamp type 1843)

#### Sensor Continuity Lamp

Indicates sensor continuity. It can be checked by shorting the sensor check terminals. (Lamp type 1843)

#### Sensor Check Terminals

Used in conjunction with a set of test leads to indicate continuity of the breaker sensors.

#### Test Plug Connector

It is important that the test plug be inserted securely in the proper holes: Clamp the assemblies together as provided to prevent misoperation.

#### Variac Control

Adjusts the level of the simulated fault current. Always start the tests with variac in the low position.

#### External Ammeter Terminals

For more precise settings an external ammeter may be used to set fault levels.

#### Meter Scale Switch

Used to change full scale currents of the meter.

#### Ammeter

The ammeter is calibrated to read full scale of the meter scale switch.

### Timer

The timer is used to indicate the length of time that the fault current persists. Please note that the timer runs when checking pick-up and it should be disregarded. Timer may be analog or digital.

### WARNING WARNING WARNING WARNING

THE CIRCUIT BREAKER TO BE TESTED SHOULD BE COMPLETELY DE-ENERGIZED OR OTHERWISE DISCONNECTED FROM THE POWER CIRCUIT FOR COMPLETE SAFETY TO TEST PERSONNEL.

When the circuit breaker is stationary mounted, it is necessary to physically disconnect the primary cables or to otherwise open the circuit on both sides of the circuit breaker.

When the circuit breaker is the drawout type, the Circuit breaker should be withdrawn to the test position to isolate the primary circuit.

When the breaker is electrically operated, the control power can be retained for ease of operation of the circuit breaker during testing.

Refer to the individual instruction books listed in Section 2.1 for guidance.

### 2.4 LONG-TIME FUNCTION (See Notes 1-5 page 5)

#### 2.4.1 PICK-UP TEST

- Set the Function Selector to LT.
- Set the Phase Selector to the desired phase.
- Operate and hold the Fault Switch and slowly adjust Variac Control until the Pick-Up Lamp lights.
- Observe meter reading and compare against proper value obtained from Table 2. Repeat for other phases.

#### 2.4.2 DELAY TEST

- Set the Function Selector to TIME.
- Set the Phase Selector to the desired phase.
- Operate and hold the Fault Switch and adjust Variac Control to the desired test current. (e.g. three times pick-up test current in Table 2.)
- Release the Fault Switch and reset the Timer.
- Operate and hold the Fault Switch until the the Open Lamp lights, the Timer stops, and the breaker trips. Check time against Table 4.
- Reset the Timer, depress the Reset Button and if desired close the circuit breaker.
- Return the Variac Control to zero (counterclockwise) at the end of the delay test.

### 2.5 INSTANTANEOUS FUNCTION

(See Notes 1-5 page 5)

#### 2.5.1 PICK-UP TEST

- Set the Function Selector to INST.
- Set the Phase Selector to the desired phase.
- Operate and hold the Fault Switch and slowly adjust the Variac Control until the Open Lamp lights and the circuit breaker trips.
- Observe the meter reading at the point where the meter reading begins to decay and compare with the proper value found in Table 2.
- Return the Variac Control to zero (counterclockwise), depress the Reset Button, and close circuit breaker if desired.
- Repeat for other phases if desired.
- Note that the INSTANTANEOUS function may not be checked at the 12X setting because the maximum SHORT-TIME setting 10X (when included) will interfere with test.

### 2.6 SHORT-TIME FUNCTION (See Notes 1-5 page 5)

#### 2.6.1 PICK-UP TEST

- Set the Function Selector to ST.
- Set the Phase Selector to the desired phase.
- Operate and hold the Fault Switch and slowly adjust the Variac Control until the Open Lamp lights and the breaker trips.
- Observe the meter reading at the point where the meter reading begins to decay and compare with the proper value obtained from Table 2.
- Return the Variac Control to zero (counterclockwise), depress the Reset Button, and close circuit breaker if desired.

#### 2.6.2 DELAY TEST

- Set the Function Selector to TIME.
- Set the Phase Selector to the desired phase.
- Operate and hold the Fault Switch and adjust the Variac Control to a current that is 150% of pick-up. (To preset test current, place pick-up pin into max. slot; then replace to original slot.)
- Release the Fault Switch and reset the Timer.
- Operate and hold the Fault Switch until the Open Lamp lights and the circuit breaker trips. The Timer will indicate the elapsed trip time. Check time against Table 4.
- Return the Variac Control to zero (counterclockwise), depress the Reset Button, and close the circuit breaker if desired.
- Repeat for other phases if desired.

## 2.7 GROUND FUNCTION (See Notes 1-5 page 5)

### 2.7.1 PICK-UP TEST

- a. Set the Function Selector to GND.
- b. Set the Phase Selector to the desired phase.
- c. Set the GND Switch in the Test position.
- d. Operate and hold the Fault Switch and slowly adjust the Variac Control until the Open Lamp lights and the breaker trips.
- e. Observe the meter reading at the point where the Meter reading begins to decay and compare with value obtained in Table 3.
- f. Return the Variac Control to zero (counterclockwise), depress the Reset Button, and close the circuit breaker if desired.
- g. Repeat for other phases if desired.

### 2.7.2 DELAY TEST

- a. Set the Function Selector to TIME.
- b. Set the Phase Selector to the desired phase.
- c. Set the GND Switch to the Test position.
- d. Operate and hold the Fault Switch and adjust the Variac Control to a current that is 150% of pick-up. (To preset test current, place pick-up pin into max. slot; then replace to original slot.)
- e. Release the Fault Switch and reset the Timer.
- f. Operate and hold the Fault Switch until the Open Lamp lights and the breaker trips. The Timer will indicate the elapsed trip time. Check time against Table 4.
- g. Return the Variac Control to zero (counterclockwise), depress the Reset Button, and close the circuit breaker if desired.
- h. Repeat for other phases if desired.

## 2.8 SENSOR CHECKS

**NOTE:** All sensors are tested as part of the complete breaker system at the factory, prior to shipment. All sensors can be individually checked as follows:

Remove the test cable from the "POWER SHIELD" terminal block.

Attach a pair of test leads to the SENSOR CHECK terminals on the "POWER SHIELD" Test Set.

## 2.8.1 SENSOR CONTINUITY

### SIGNAL SENSORS

- a. Attach one of the test leads to terminal five (5) of the "POWER SHIELD" terminal block.
- b. Remove the wire from terminal eight (8) of the "POWER SHIELD" terminal block and hold the remaining test lead TO THE WIRE. The sensor continuity lamp should light brightly to indicate continuity.
- c. Replace the wire to terminal eight (8).
- d. Repeat the test for terminals seven (7) and six (6).
- e. If the "POWER SHIELD" unit is a four wire system with ground protection, repeat the test on terminal four (4) to check continuity of the neutral sensor.

### POWER SUPPLY SENSORS

- a. Attach one of the test leads to terminal fourteen (14) of the "POWER SHIELD" terminal block.
- b. Remove the wire from terminal eleven (11) of the "POWER SHIELD" terminal block and hold the remaining test lead TO THE WIRE. The sensor continuity lamp should light brightly to indicate continuity.
- c. Replace the wire to terminal eleven (11).
- d. Repeat the test for terminals twelve (12) and thirteen (13).

## 2.8.2 SENSOR GROUNDING

To ensure that all sensors are electrically isolated from ground, the above tests can be repeated from each sensor terminal ( 8, 7, 6, 4, 11, 12, and 13 ) to breaker frame. The continuity lamp should NOT light.

## 2.9 HIGH LOAD ALARM TEST

- a. Set the Function Selector to TIME.
- b. Set the Phase Selector to the desired phase.
- c. Operate and hold the Fault Switch and adjust the Variac Control clockwise until the contacts of terminals A and B close. (Terminals A and B are located on side of case.)
- d. Observe the meter reading and compare with the proper value obtainable from Table 2.

**TABLE 2 — LONG-TIME, INSTANTANEOUS AND SHORT-TIME PICK-UP CURRENTS ( $\pm 15\%$ )**

The test current values listed are secondary amperes.

Breaker Rating	Ampere Tap	Test Current (Amps)*	Test Currents (For Indicated Multiples of AMP Tap Setting)							
			2	3	4	5	6	8	10	12
K-600 & 800S K-Don 600 & 800S (225A Sensors)	50	0.50	1.00	1.50	2.00	2.50	3.00	4.00	5.00	6.00
	70	0.70	1.40	2.10	2.80	3.50	4.20	5.60	7.00	8.40
	100	1.00	2.00	3.00	4.00	5.00	6.00	8.00	10.00	12.00
	150	1.50	3.00	4.50	6.00	7.50	9.00	12.00	15.00	18.00
	225	2.25	4.50	6.75	9.00	11.25	13.50	18.00	—	—
K-600 & 800S K-Don 600 & 800S (600A Sensors)	250	1.00	2.00	3.00	4.00	5.00	6.00	8.00	10.00	12.00
	400	1.60	3.20	4.80	6.40	8.00	9.60	12.80	16.00	19.20
	600	2.40	4.80	7.20	9.60	12.00	14.40	19.20	—	—
K-800S K-Don-800S (800A Sensors)	300	1.00	2.00	3.00	4.00	5.00	6.00	8.00	10.00	12.00
	600	2.00	4.00	6.00	8.00	10.00	12.00	16.00	—	—
	800	2.67	5.34	8.01	10.70	13.40	16.00	21.40	—	—
K-1600S K-Don-1600S (600A Sensors)	250	1.00	2.00	3.00	4.00	5.00	6.00	8.00	10.00	12.00
	400	1.60	3.20	4.80	6.40	8.00	9.60	12.80	16.00	19.20
	600	2.40	4.80	7.20	9.60	12.00	14.40	19.20	—	—
K-1600S K-Don-1600S (1600A Sensors)	600	0.75	1.50	2.25	3.00	3.75	4.50	6.00	7.50	9.00
	1000	1.25	2.50	3.75	5.00	6.25	7.50	10.00	12.50	15.00
	1600	2.00	4.00	6.00	8.00	10.00	12.00	16.00	20.00	—
K-2000S	800	1.00	2.00	3.00	4.00	5.00	6.00	8.00	10.00	12.00
	1200	1.50	3.00	4.50	6.00	7.50	9.00	12.00	15.00	18.00
	2000	2.50	5.00	7.50	10.00	12.50	15.00	20.00	—	—
K-3000S	2000	1.00	2.00	3.00	4.00	5.00	6.00	8.00	10.00	12.00
	3000	1.50	3.00	4.50	6.00	7.50	9.00	12.00	15.00	18.00
K-4000S	3000	1.50	3.00	4.50	6.00	7.50	9.00	12.00	15.00	18.00
	4000	2.00	4.00	6.00	8.00	10.00	12.00	16.00	20.00	—

\*Based on 1.0 pick-up setting. For other pick-up settings, multiply the 1.0 pick-up value by the pick-up tap setting.

i.e. 0.8 pick-up setting on a 1600 ampere tap of a 1600 breaker rating.  
 $0.8 \times 2.00A = 1.60A$  Test Current.

**TABLE 3 — GROUND PICK-UP CURRENTS ( $\pm 15\%$ )**

The test current values listed are secondary amperes.

Breaker Rating	Ground Pickup Plug Setting	Test Current (Amps)
K-600 & 800S K-Don 600 & 800S (225A Sensors)	1	1.0
	3	3.0
	6	6.0
	12	12.0
K-600 & 800S K-Don 600 & 800S K-1600S K-Don-1600S (600A Sensors)	1	0.4
	3	1.2
	6	2.4
	12	4.8
K-800S K-Don-800S (800A Sensors)	2	0.67
	4	1.33
	6	2.00
	12	4.00
K-1600S K-Don-1600S (1600A Sensors) & K-2000S	3	0.375
	6	0.75
	9	1.125
	12	1.5
K-3000S & K-4000S	5	0.25
	8	0.4
	10	0.5
	12	0.6



**TABLE 4 — TRIP TIMES**

Test	Test Current	Time Delay in Seconds		
		Min	Int	Max
Long-Time Delay	3 x LONG-TIME pick-up setting. Set SHORT-TIME and INSTANTANEOUS pick-up above test current by placing plugs at maximum, for test purpose only. Return plugs to proper position when test is concluded. Defeat ground trip function for this test as indicated in Note 1. (See page 5)	SS-3, SS-4, SS-5		
		8-12	20-30	60-98
		SS-13, SS-14, SS-15		
		16-24	40-60	120-196
Short-Time Delay	1.5 x SHORT-TIME pick-up setting. Set INSTANTANEOUS pick-up above test current by placing plug at maximum, for test purpose only. Return plug to proper position when test is concluded. Defeat ground trip function for this test as indicated in Note 1. (See page 5)	All Devices		
		.08-.17	.20-.32	.35-.50
Instantaneous Delay	1.5 x INSTANTANEOUS pick-up setting.	All Devices		
		No noticeable delay		
Ground Delay	1.5 x GROUND pick-up setting.	All Devices		
		Min	Int	Max
		.08-.17	.20-.32	.35-.50

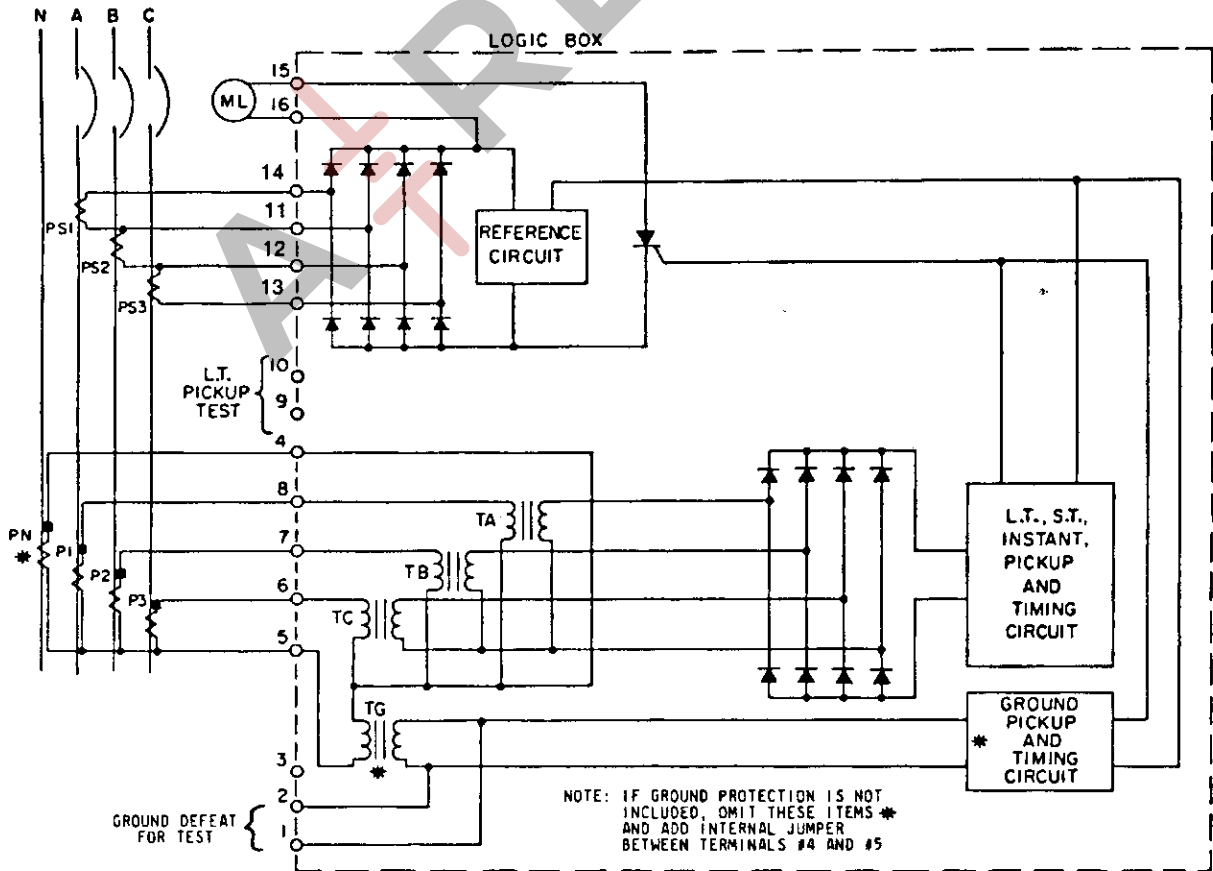

**Fig. 3 — Typical Wiring Diagram of Standard 3- or 4-Wire System with Ground Fault Protection**

### 3.0 APPENDIX

#### 3.1 PRIMARY CURRENT TESTING

The primary test method is desirable periodically, when the proper high current test equipment is available, since all elements of the circuit breaker are tested at one time, simulating actual service conditions as closely as possible.

**NOTE:** It is pointed out that when such a low voltage — high current test set is used, the resultant test current is not perfectly sinusoidal. This can cause apparent errors in test results, particularly when checking the GROUND function, since solid-state trip devices are designed and tested in the factory in terms of rms sinusoidal current, in accordance with standards.

However, even with the deficiencies noted, the primary test method is still valuable in checking all components in the circuit breaker from terminal to terminal.

If more accurate measurements are desired, the following steps should be taken

a. Remove wires from terminals 11, 12, 13 & 14 of the logic box. Short out these four wires for the duration of the tests.

b. Apply an external auxiliary voltage source (14 Vac  $\pm 20\%$ ) through a 52/a breaker auxiliary contact to terminals 11 & 14 of the logic box.

The following general guide lines are provided for information .

1. Test Equipment—The test equipment should be a 60 Hz. power supply capable of supplying single phase, high current at low voltage. Current output should be adjustable with a minimum current requirement of 600% of maximum sensor rating. This is based on checking the instantaneous element for pick-up at approximately four times rating and checking the short-time delay element set at four times rating with current at 1 1/2 times the setting. The test equipment should be capable of maintaining the instantaneous and short-time test currents for a minimum of two seconds which is the time allotted for adjusting the test equipment to the correct current values. The equipment should contain a timer which will operate during current flow and be capable of accurately measuring times between .05 and 300 seconds.

2. Connect the upper and lower breaker terminals of one pole to the test unit. If the breaker and test unit are not equipped with stab adapters, use cable or bus of sufficient size and as short as possible to hold heat rise and voltage drop to a minimum.

3. After each test that results in the breaker tripping, reclosing the breaker is required before proceeding with the next test.

4. Since much of the testing is done with currents exceeding the continuous current rating of the circuit breaker, care should be exercised in not overheating it. Allow sufficient cooling time between tests.

5. After conclusion of the tests, make sure the tap plugs

are reset to the required operating setting.

6. In order to save time and to keep the breaker from overheating, the tests are made at one setting. From experience, if the solid-state trip device checks out at one calibration setting with an overcurrent through the breaker, the device will also check out at other calibration settings and overcurrents. Therefore, 300% over-current is used as representative far long time delay and 150% (of SHORT-TIME calibration setting) for short-time delay testing.

7. Due to extensive equipment required, field testing for resettable delay is not justified and, therefore, not covered by this procedure.

8. Clean Contacts—The arc contacts will become marked from repeated tests and at the low voltage test values, the current tends to mark the mains as well. Clean with nonmetallic material such as "Scotch Brite." Blow residue from the breaker before placing in service.

#### Note For Testing Models Equipped With Ground

For "POWER SHIELDS" so equipped, the ground-trip function must be defeated in order to test the other trip functions. This is done by placement of a jumper-wire on the "POWER SHIELD" front panel, between terminals 1 and 2. To test the LONG-TIME, SHORT-TIME, and INSTANTANEOUS functions, temporarily connect this jumper. Remove it to test the ground trip function and to place the breaker in service.

As an example of this test procedure, consider a K-2000S breaker equipped with type SS-5G "POWER SHIELD" trip device. The settings are:

LONG-TIME: Pick-up—1,600 amps (0.8 X 2000) Delay—Min. Band

SHORT-TIME Pick-up—8,000 amps (4 X 20000) Delay—Int. Band

INSTANTANEOUS Pick-up — 20,000 amps (10 X 2000)

GROUND: Pick-up — 600 amps Delay — Max. Band  
When testing LONG-TIME, SHORT-TIME and INSTANTANEOUS functions, place the jumper between terminals 1 and 2, to defeat ground.

For the LONG-TIME test use test current of  $3 \times 1600 = 4800$  amps. Since this is below the SHORT-TIME and INSTANTANEOUS settings, they need not be changed for the test. The breaker should open after the expiration of the LONG-TIME, minimum delay of 8 to 12 seconds.

To test the SHORT-TIME function, use a test current of  $1.5 \times 8,000 = 12,000$  amps. The delay should be from .20 to .32 seconds.

Use a test current of  $1.5 \times 20,000 = 30,000$  amps to test the INSTANTANEOUS. Delay should be 0.06 seconds plus test set timing error, or less.

Remove the jumper between terminals 1 and 2. Use a test current of  $1.5 \times 600 = 900$  amps to test the ground. The delay should be between .35 and .50 seconds.

In addition to the delay test outlined above, the pick-up currents may also be checked, if desired. The tolerance on

all pick-ups ( LONG, SHORT, and INSTANTANEOUS) is plus or minus 10%. The SHORT-TIME, INSTANTANEOUS, or GROUND trip pick-up may be measured by increasing the current gradually until the breaker trips. The LONG-TIME pick-up may be accurately determined by connecting a VOM from terminal 10 to 9 (10 plus). Pick-up is that current at which the VOM just deflects. If allowed to persist long enough, the breaker will eventually trip after the VOM is removed.

**3.2 PRIMARY TESTING OF A 4-WIRE DOUBLE-ENDED SUBSTATION (DE4W) BREAKER**

Main and tie breakers of a 4-wire double-ended system

sense ground faults from currents through the neutral sensor only. A ground fault current can be simulated using a spare neutral sensor around the current Source bus, with the sensor secondary connected to terminals 4 and 5 of the "POWER SHIELD" logic box as shown below.

If a spare neutral sensor is not available, an alternate method can be employed as follows. Connect the left pole of the breaker, as viewed from the front, to the current source and move the lead from terminal 6 to terminal 5 of the "POWER SHIELD" logic box.

For either method use ground test procedure described in Section 3.1.

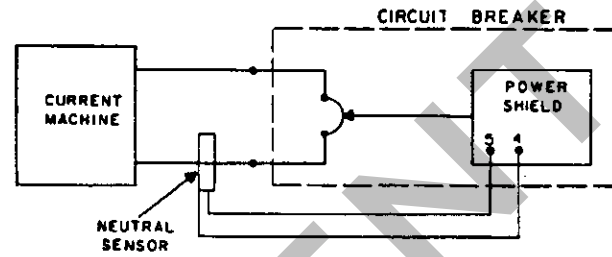
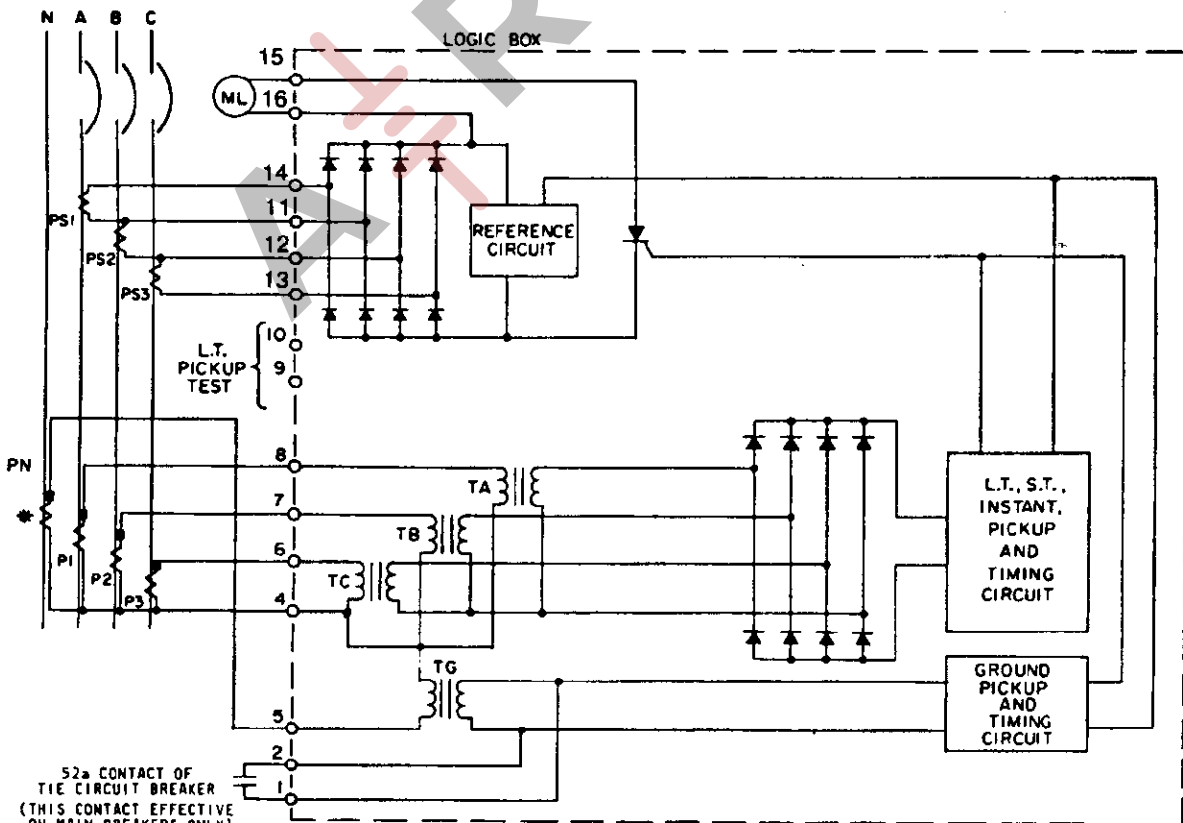

Fig. 4 — DE4W Testing



\* REFER TO FIG. 6 FOR LOCATION OF NEUTRAL SENSORS

Fig. 5 — Typical Wiring Diagram of Main and Tie Breakers for 4-Wire Double-Ended Systems with Ground

### 3.3 DESCRIPTION OF GROUND FAULT PROTECTION SYSTEM FOR FOUR-WIRE DOUBLE-ENDED SUBSTATION

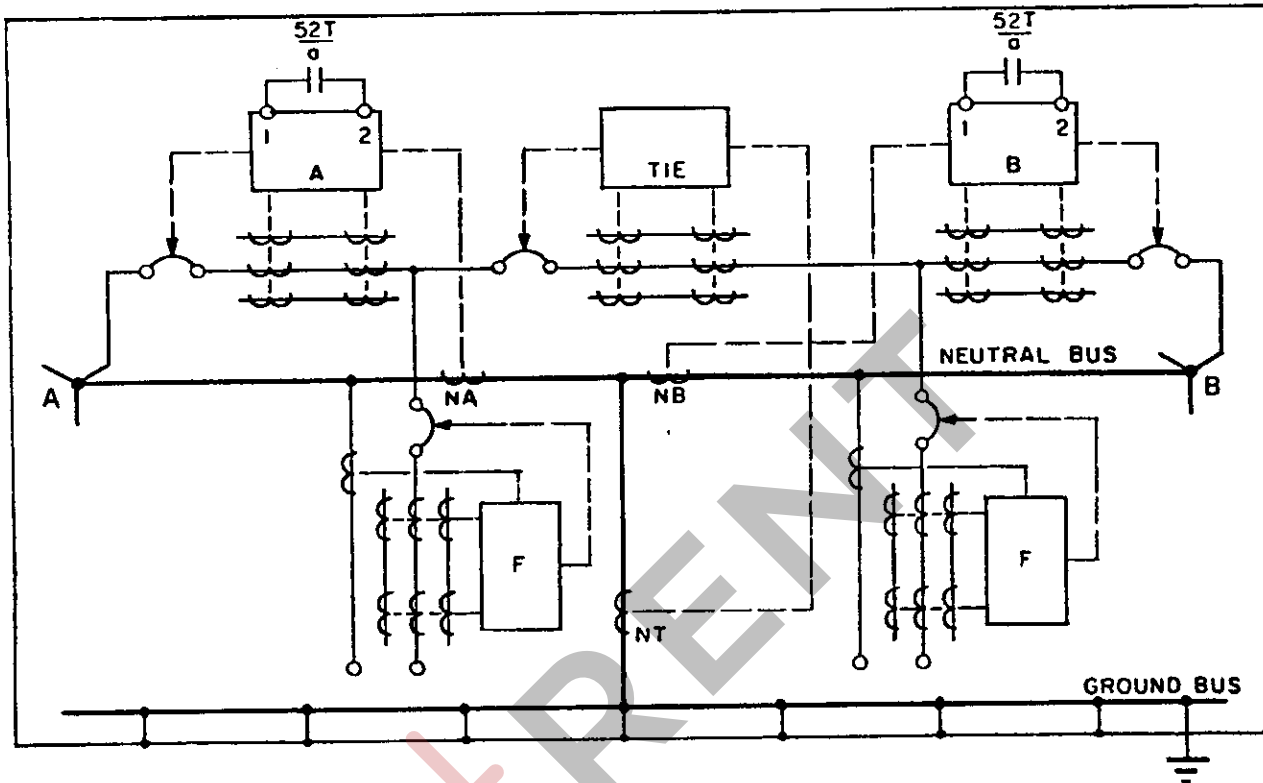

Fig. 6 — Four-Wire Double-Ended System

#### FOUR-WIRE DOUBLE-ENDED SYSTEMS

The above system is used for ground fault protection on a four-wire double-ended substation with tie breaker. This system assures that a bus ground fault will cause only one main breaker to trip, leaving the other main breaker in service. The ground trip signal of each main breaker is controlled by a 52/a contact of the tie breaker. Therefore, the main breakers can trip on a ground fault only when the tie breaker is open.

The following is a typical ground fault sequence. Assume that both mains and the tie breaker are closed and a ground fault occurs on bus A. The ground fault current will flow to the fault point returning via the ground bus, up the neutral

to ground bus connection to the neutral points of transformers A & B. All three neutral sensors NA, NB and NT will sense the fault current, but only the tie breaker will trip since the ground function of the main breakers is controlled by the tie breaker, 52/a contact. After the tie breaker trips, the fault current will continue to be sensed only by the main breaker "A" neutral sensor (NA). The main breaker "A" will trip, interrupting service to the feeders on side "A". Main breaker "B" remains closed, and bus "B" remains energized.

The feeder breakers and the tie breaker must be coordinated time-wise to insure that the feeder breaker will clear a ground fault before the tie breaker trips on faults downstream from the feeder breakers.

TEST SHEET

DATE \_\_\_\_\_

TESTER \_\_\_\_\_

BREAKER TYPE \_\_\_\_\_

TRIP DEVICE TYPE \_\_\_\_\_

TRIP DEVICE SERIAL NO. \_\_\_\_\_

LONG-TIME (TAP \_\_\_\_\_ - PLUG \_\_\_\_\_ - MINIMUM DELAY)

PICKUP:\* \_\_\_\_\_ amps (PHASE A)

\_\_\_\_\_ amps (PHASE B)

\_\_\_\_\_ amps (PHASE C)

TIME: \_\_\_\_\_ seconds

INST. (PLUG \_\_\_\_\_ )

PICKUP: \_\_\_\_\_ amps

SHORT-TIME (PLUG \_\_\_\_\_ - MINIMUM DELAY)

PICKUP: \_\_\_\_\_ amps

TIME: \_\_\_\_\_ seconds

GROUND (PLUG \_\_\_\_\_ - MINIMUM DELAY)

PICKUP: \_\_\_\_\_ amps

TIME: \_\_\_\_\_ seconds

SENSOR CHECKS \_\_\_\_\_ OK \_\_\_\_\_ NOT OK

\*Different Phases need only be checked once.  
Run remaining tests at any one Phase.

### TEST SET TROUBLE-SHOOTING GUIDE

This list of reference voltages applies only for problems in the tester.  
BE SURE THE PROBLEM IS NOT CAUSED BY THE POWER SHIELD SOLID-STATE TRIP DEVICE.

Printed Ckt. Board Test Points	Breaker Position	Voltage	Printed Ckt. Board Test Points	Breaker Position	Voltage
3 to 21	Closed	120 Vac	14 to 17	Closed	33 Vdc
18 to 19	Closed	27.5 Vac	14 to 17	Open	29 Vdc
10 to 11	Closed	1.9 Vdc	20 to 17	Closed	25 Vdc
10 to 11	Open	0 Vdc	20 to 17	Open	65 Vdc
12 to 17	Closed	33 Vdc	25 to 17	Closed	0 Vdc
12 to 17	Open	29 Vdc	25 to 17	Open	23 Vdc
13 to 17	Closed	25.5 Vdc	28 to 17	Closed	33 Vdc
13 to 17	Open	23 Vdc	28 to 17	Open	28 Vdc

### EXAMPLE OF COMPLETED TEST SHEET\*

IB 6.1.2.7-4  
PAGE 11

TEST SHEET

DATE NOVEMBER 6, 1974  
TESTER JOHN DOE

BREAKER TYPE K-16005 TRIP DEVICE TYPE SS5G3  
TRIP DEVICE SERIAL NO. 20337

LONG-TIME (TAP 1600 - PLUG 1.0 - MINIMUM DELAY)  
PICKUP: \* 2.05 amps (PHASE A)  
2.10 amps (PHASE B)  
2.05 amps (PHASE C)  
TIME: 10.8 seconds

INST. (PLUG 4.0)  
PICKUP: 8.4 amps

SHORT-TIME (PLUG 2.0 - MINIMUM DELAY)  
PICKUP: 4.2 amps  
TIME: 0.13 seconds

GROUND (PLUG 3.0 - MINIMUM DELAY)  
PICKUP: 0.41 amps  
TIME: 0.12 seconds

SENSOR CHECKS  OK  NOT OK

\*Different Phases need only be checked once.  
Run remaining tests at any one Phase.

\* TEST SHEET ON PAGE 13 CAN BE DUPLICATED FOR CUSTOMER'S USE

TEST SET SCHEMATIC DIAGRAM

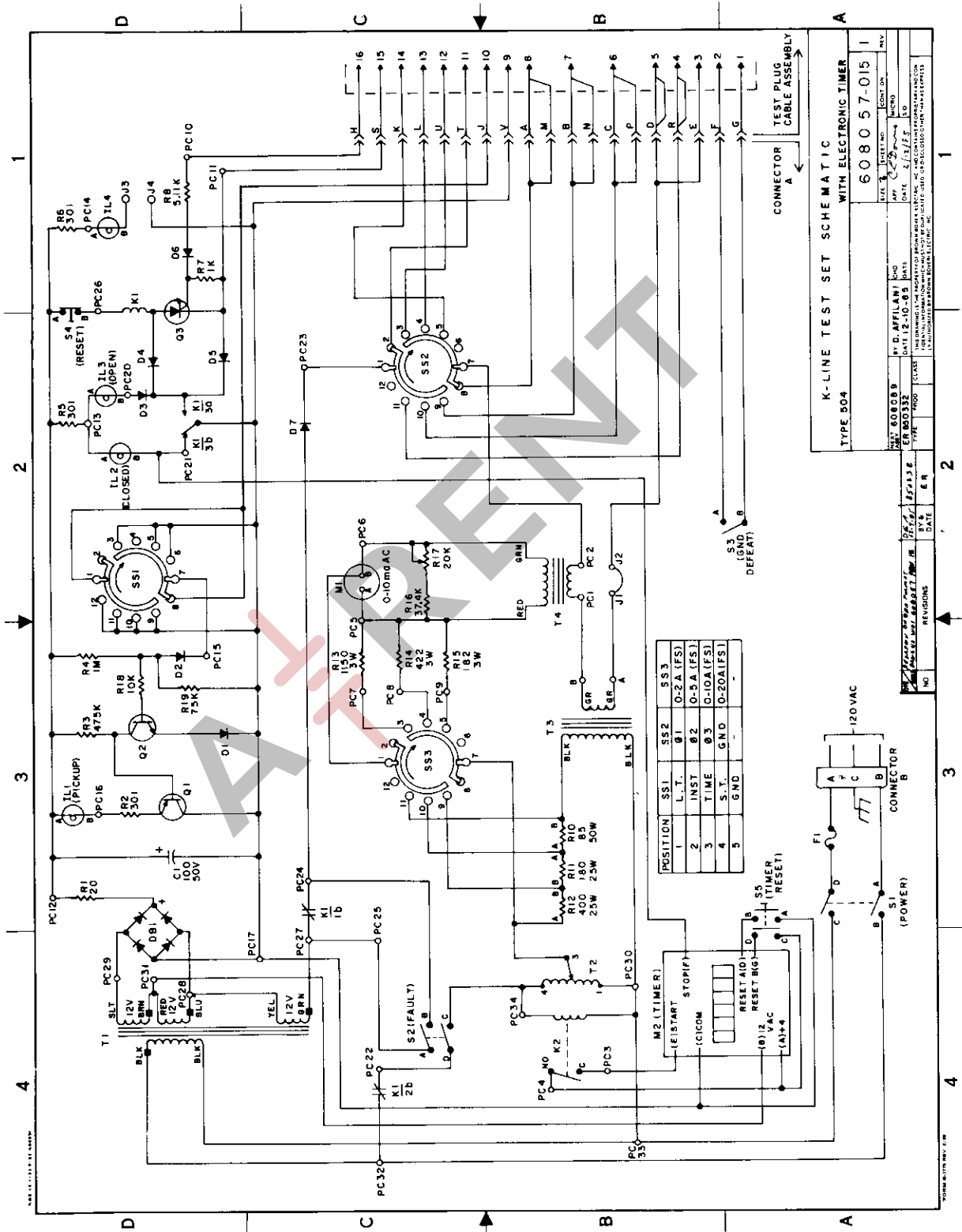

**K-LINE TEST SET SCHEMATIC WITH ELECTRONIC TIMER**

TYPE 504

608057-015 I

REV. 408089  
DATE 12-10-83  
BY 4  
DATE

REVISIONS

NO. REVISIONS

BY 4  
DATE

APP. 608089  
DATE 2/1/85  
BY 4  
DATE

FOR INFORMATION ONLY: THIS SCHEMATIC IS A REVISION OF THE SCHEMATIC FOR TYPE 504 (IB 6.1.2.7-4) WHICH IS OBSOLETE.

1. CONSULT THE SCHEMATIC FOR THE SCHEMATIC FOR TYPE 504 (IB 6.1.2.7-4) WHICH IS OBSOLETE.

FORM 6078 REV. 7.80

# POWER SHIELD TIME-CURRENT CHARACTERISTICS

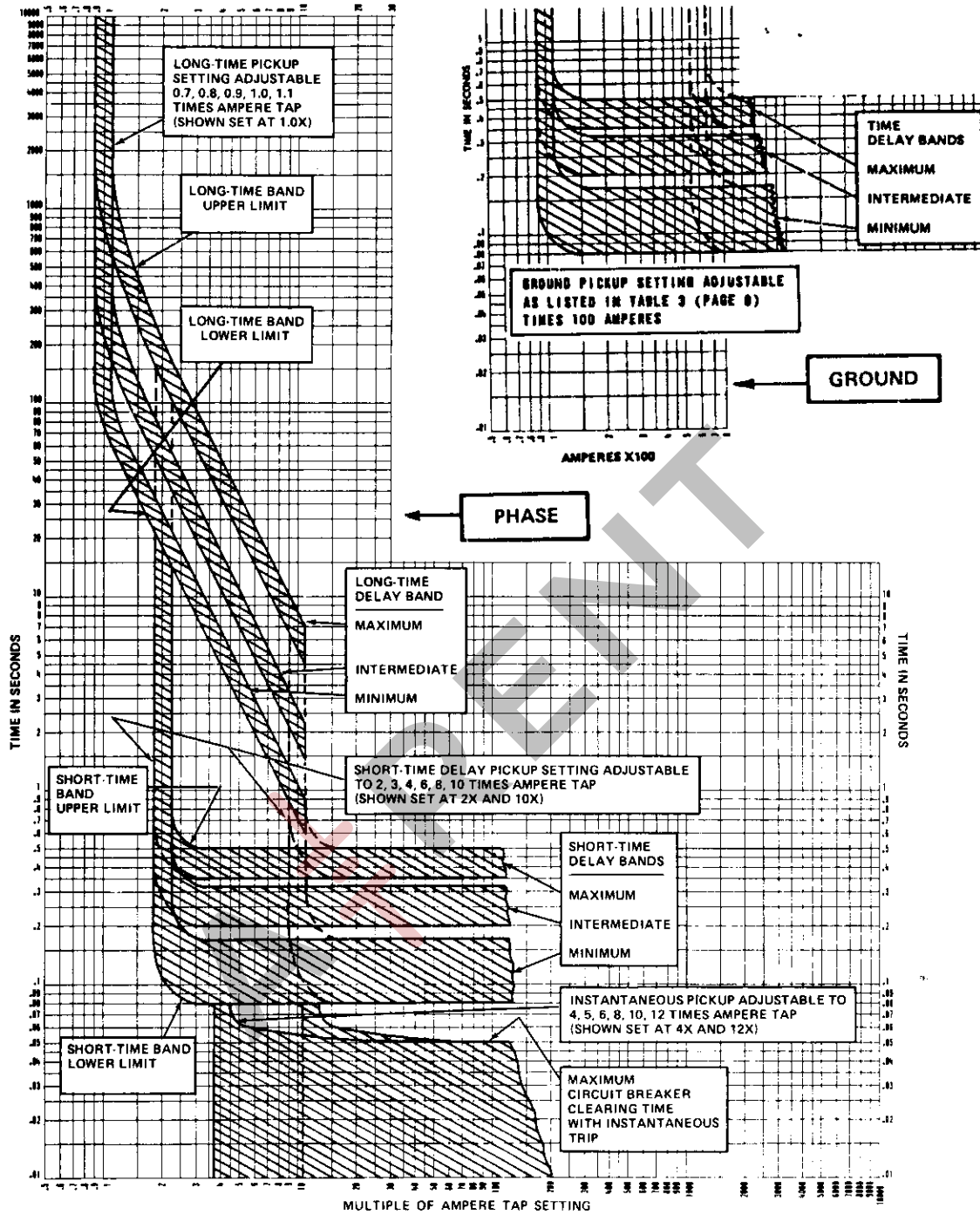

ASEA BROWN BOVERI, INC.  
ABB Power Distribution Inc.  
Circuit Breaker Division  
P.O. Box F-7  
Florence, South Carolina 29501

Phone: (803) 665-4144  
Telecopier: (803) 664-0520

New  
Printed in U.S.A. 1M 0190

**A-RENT**

a-rent.com

(IL) 630.748.8900

(TX) 713.564.8900

sales@a-rent.com